

## SECTION 7 - MERIDIA ADJUSTMENT PROCEDURES WITH DSD 412

### Hoistway Verification

#### Inspection Operation

1. Remove the car gate and door lock jumpers that were installed during temporary operation.
2. Remove any safety circuit jumpers that were installed during temporary operation.
3. Remove jumpers from normal and slowdown limits.
4. Remove temporary run cord and any wiring used to make temporary operation available.
5. Verify all Inspection switches are in the Inspection Mode and all safety circuit switches are in their correct positions.
6. Verify that the car is now ready for inspection operation via the top of car run station. [Refer to Table A.] All Inputs/Outputs are High. (High is 120 VAC for all except DRVS and NP which is 24 VDC.)

**Note:** If laptop with Wizard 15 software or RVU Unit is not available, use CCU to navigate and display the status of I/O. (See section 11 page 3).

I/Os required to run Car Top Inspection		
Port	Location	Module
VIC	SDM 1	UNL
VIC	SDM2	SU1
VIC	SDM3	SU2 (If required)
VIC	SDM5	GL
VIC	SDM6	SD2 (If required)
VIC	SDM7	SD1
VIC	SDM 8	DNL
VIC	ISM 5	DLS
VIC	SM1 1	GV
VIC	SM1 4	CGS
VIC	SM1 7	DRV
VIC	SM1 8	GLB
VIC	SM2 1	CG
VIC	SM2 2	DL
VIC	SM2 7	RDY
VIC	DM 3	DRVS
VIC	EM 5	NP
VIC	CM2 4	GLT (output)
TOC	HSM 1	CS
TOC	HSM 2	ICS
TOC	HSM 4	HS
TOC	HSM 1	CS
TOC	RLM1	TCI

**Table A** **Note:** Check additional modules if rear doors or freight doors are used.

#### Door and Gate Check

While running from Car Top inspection switches, open each door and gate to verify the car stops.

#### Safety Switch Check

1. While running the car, verify that each safety circuit device stops the car.
2. Verify that all limit switches are activated mechanically. (Example: Top final limit is broken by cam on car.)

#### Normal Limits Check

1. Verify that that top directional switch stops the car from running up and the bottom directional switch stops the car when running down.
2. Verify that the directional switches open when the car is within 1 inch of the floor level.

#### Vane and Switch Placement

1. If using encoder leveling (No tape), verify ULZ and DLZ sensors are moved to their maximum spacing.

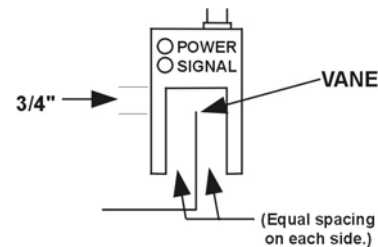

**Figure 7-1**

2. Verify that a floor leveling vane has been placed at each floor.

**Note:** Vanes are mounted equally between the ULZ and DLZ sensors with the car at floor level. Vanes should be mounted within +/-0.50 inches of floor level or a new hatch scan will need to be done after the car is setup.



- Verify that the ETS vanes are mounted at the required distance from both terminal floors. [See Table B.]

Meridia ETS Limit Distances* Version 7 and later				
Speed	ETS 1,5	ETS 2,6	ETS 3,7	ETS 4,8
50 FPM	4" (10cm)			
75 FPM	5" (13cm)			
100 FPM	7"(18cm)			
150 FPM	9"(23cm)			
200 FPM	5"(13cm)	17"(43cm)		
250 FPM	7"(18cm)	21"(53cm)		
300 FPM	7"(18cm)	21"(53cm)	34"(86cm)	
350 FPM	14"(36cm)	28"(71cm)	42"(107cm)	
400 FPM	14"(36cm)	28"(71cm)	42"(107cm)	56"(142cm)
450 FPM	15"(38cm)	30"(76cm)	45"(114cm)	60"(152cm)
500 FPM	16"(41cm)	32"(81cm)	48"(122cm)	64"(163cm)

**Table B**

**Note:** Distance is measured from the center of the selector box to the leading edge of the vane when the car is at floor level. See prints for more detail.

- Verify the terminal slowdown switches open at the correct distance from the terminal floor +/-2". [See Table C.]
- If using a tape, refer to Magnet Placement section on page 7-5.

**Slowdown Distance**

FPM	(m/s)	SLD1 Distance	TSV1 Value	SLD2 Distance	TSV2 Value
50	(0.25)	3" (8cm)	40		
75	(.375)	6" (16cm)	70		
100	(.50)	9.5" (25cm)	90		
150	(.75)	15" (39cm)	120		
200	(1.0)	24.5" (63cm)	160		
250	(1.125)	30.5" (78cm)	210		
300	(1.50)	43" (110cm)	260		
350	(1.75)	49" (125cm)	310		
400	(2.0)	41" (105cm)	310	62.5"(159cm)	360
450	(2.25)	41" (105cm)	310	68.5" (174cm)	410
500	(2.5)	41" (105cm)	320	84" (214cm)	460

**Table C**



## DPP Setup

### AC Voltmeter Method

1. Using a voltmeter on the **AC scale** to verify the DPP signals, connect it between DPP1+ (positive lead) and DPP1- (negative lead) on the CPE or CTI boards.
2. Run the car Up and Down on Inspection at 50 FPM.
3. Adjust the meter settings to monitor the Pulsed voltage. Reading should be 2.7 VAC +/-0.5 VAC.
4. If not in tolerance, adjust the distance between the sensor and the magnet.

**Note:** *Adjust the sensors IN or OUT 360° increments. Failure to do so can result in improper selector operation.*

5. Repeat steps 2-4 until the reading is in tolerance.
6. Repeat step 1-5 for DPP2 – DPP2/.

### Oscilloscope Method

An alternate and more accurate method of verifying the DPP signals is using the Oscilloscope method. It is the preferred method but can be bypassed if an Oscilloscope is not available.

1. With an isolated dual channel oscilloscope, connect the one channel to DPP1+ and the other channel to DPP2+ [with ground on TP4 (GND)] on the CPE or CTI boards.
2. Run the car Up and Down on Inspection at 50FPM.

3. Verify the proper waveforms and amplitude of the square waves are correct. The Oscilloscope Time/div setting should be set at 0.5 seconds/div.

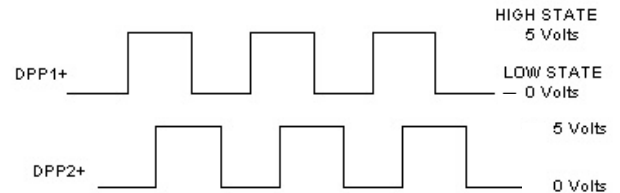

**Figure 7-2**

4. Adjust the sensors and magnets to obtain a 50% duty cycle. Signal should be high for the same amount of time as it is low.
5. Verify the two signals are 90° out of phase with each other.

Verify the following conditions **do not** exist in the DPP signals on the display.

- Excessive Noise Spikes
- Ringing or Oscillations
- Distortion

(See Figure 7-3 for examples of incorrect waveforms.)

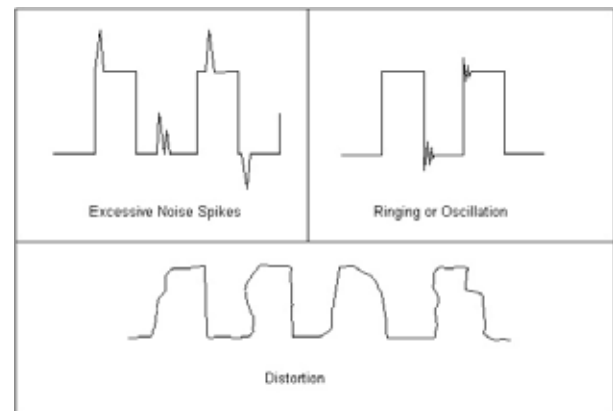

**Figure 7-3**

If any of these conditions exist, verify the following:

- The DPP signal is wired (continuous run) through the twisted shielded cable.
- The shielded cable is grounded on the controller ground terminal.
- The DPP wiring is not run in the same traveling cable with the high voltage signals (over 120 VAC).
- The minimum wire gauge for the DPP signal is 18 AWG.

Correct as necessary.



**Tape Car Position Transducer**

SIZE OF THE STRUT CHANNEL: 1 1/2" x 3/4" x 24" LONG  
(3.8 cm x 1.9 cm x 61 cm)

SIZE OF THE NUT 3/4" (1.9 cm)

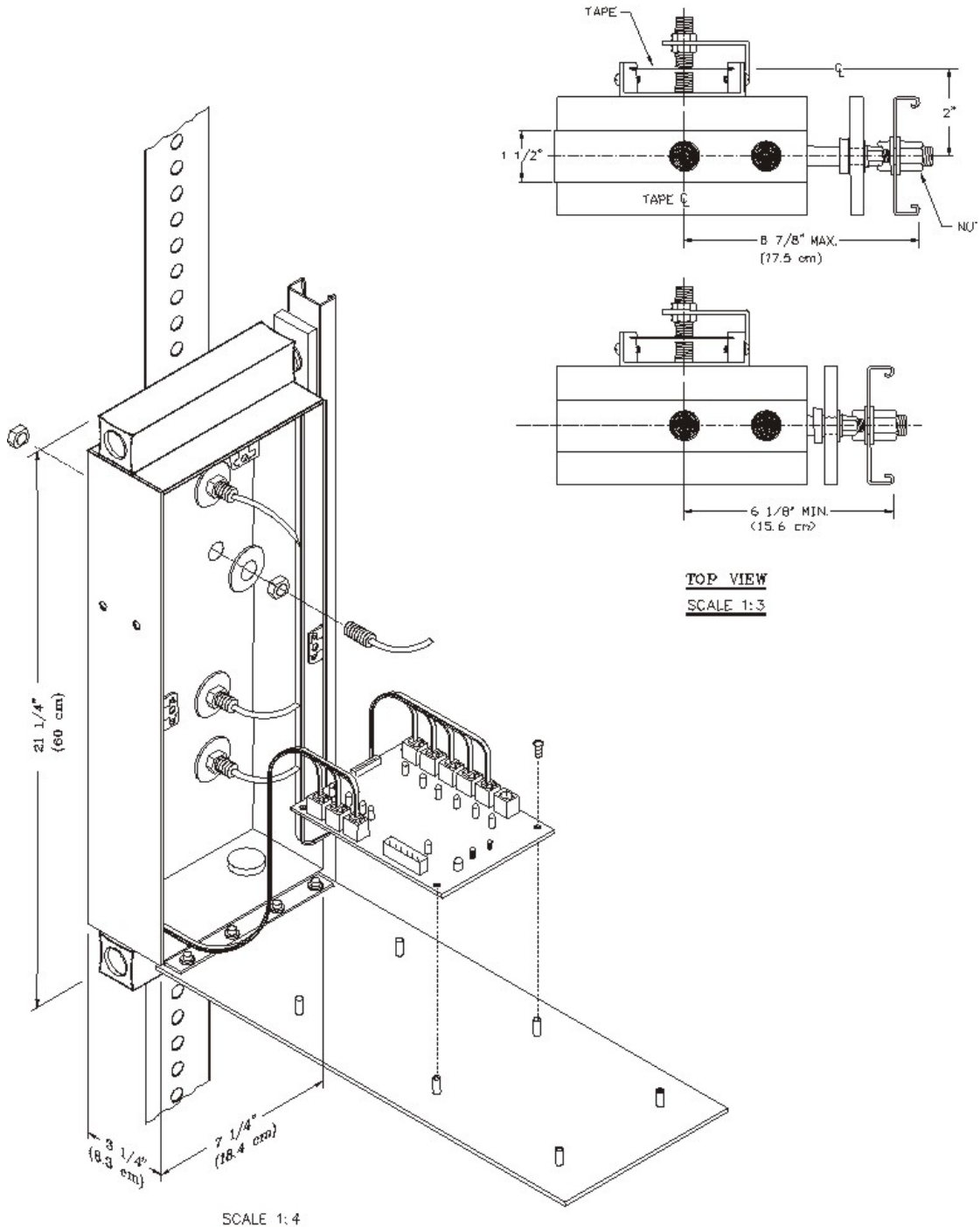

Figure 7-4



**Magnet Placement (when using Tape)**

The Meridia tape system incorporates a series of magnets for leveling and floor identification. The magnets consist of a 12" Leveling Magnet and 3" Parity Magnets. Use the following procedure for placing magnets.

1. Place the car floor exactly floor level.
2. Scribe a mark across the tape that is even with the top of the CPT.

**Note: Do not mark across the bearing box.**

3. Using the template provided, place the template on the right side of the tape.
4. Again aligning the top of the template to the scribed mark. Place the 12" magnet at the position shown on the template with its white mark outward.

5. Repeat until all floors have magnets installed.

**Door Operator Check**

Setup the door operation per manufacturer specifications.

**Note:** *If using a CEC supplied Door Board refer to appendix for Operator setup instructions.*

**Door Limit Check**

Verify the following modules:

PARAMETER	OPEN	HALF OPEN	CLOSED
DOL	LOW	HIGH	HIGH
DLC	HIGH	HIGH	LOW
DL6	HIGH	HIGH	LOW

*Table D*

**CPE Communications Check**

In the top of the car box, plug the battery into the CPE board and check CPE communication according to the communications status chart. [See Table E.]

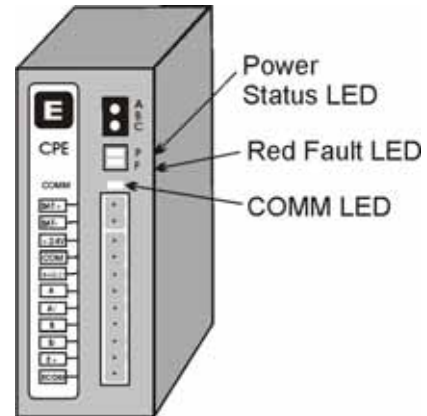

*Figure 7-5*

**Communications Status**

The Power Status LED blinks as follows:		
MODE	24V+	BATTERY
Solid	OK	OK
Double Blink	OK	Testing Battery
Fast Blink	OK	Charging Battery
Slow Blink	Fail	OK using battery power
Off	Look for Red Fault LED	
Red Fault LED Status:		
MODE	OPERATION	
Single Blink	Board in reset	
Double Blink	Battery fail or battery unplugged	
Off	Look at power status	
Comm LED Status:		
MODE	OPERATION	
Off	NO COMM to motor room	
Blink	COMM OK to motor room	

*Table E*

**Machine Room Verification**

1. Place all **Car inspection** switches in the automatic position.
2. Place the car on independent service using key switch in car or jump terminal 8 of the CFM board to VTC.

**Note:** *CFM board is normally found in COP.*

3. Verify the car will run the Up and Down using panel test buttons.



4. In the **Car Hoistway** submenu, set the TSV and ESV parameters to temporary values as follows:

**If one slowdown switch is used:**

TSV 1 = Contract speed minus 10 FPM.  
ESV 1 = Contract speed minus 10 FPM.

**If two slowdown switches are used:**

TSV 2 = Contract speed minus 10 FPM.  
ESV 2 = Contract speed minus 10 FPM.  
TSV 1 = Contract speed minus 20 FPM.  
ESV 1 = Contract speed minus 20 FPM.

5. In the **Car Hoistway** menu, set the ETV parameters as follows:

**One Vane:**

ETV 1 = Contract speed minus 10 FPM

**Two Vanes:**

ETV 2 = Contract speed minus 10 FPM  
ETV 1 = Contract speed minus 20 FPM

**Three Vanes:**

ETV 3 = Contract speed minus 10 FPM  
ETV 2 = Contract speed minus 20 FPM  
ETV 1 = Contract speed minus 30 FPM

**Four Vanes:**

ETV 4 = Contract speed minus 10 FPM  
ETV 3 = Contract speed minus 20 FPM  
ETV 2 = Contract speed minus 30 FPM  
ETV 1 = Contract speed minus 40 FPM

6. Go to the **Car Commands** submenu and scroll to **WRT** and press <ENTER>.

**Counter-weighting**

**Note:** *Until the brake is fully adjusted in the next step, extreme care should be taken when loading and unloading weights in car and counterweight.*

1. Place the balanced load on elevator. This is normally between 40 to 45% of capacity. (Example: 3000 lbs. x 45% =1575 lbs.)
2. Set the car inspection speed to 20 FPM.
3. Set Drive SCVD by accessing Function 611 to display motor current at D2 of Drive.
4. Run the car through the center of the hoistway in both directions. Note the current in both directions while running the car.

**Note:** *If current is within 2-3 Amps. of each other, the car is counter balanced sufficiently.*

*If the current is larger in the up direction, then weights must be added to the counterweight.*

*If the current is larger in the down direction, then weights must be removed from the counterweight.*

5. Remove or add counterweights as necessary until current readings are equal in both directions.

**Note:** It is extremely important that the elevator is counter-balanced in order for the drive to operate correctly.

**Brake Setup**

1. Move the elevator to the lowest landing and verify the brake can hold 125% of capacity by adjusting the brake spring tension.
2. Once the brake spring has been adjusted place the balanced load on the elevator.
3. Verify parameter BMV is per power distribution print and BMA is set to maximum amps. used by brake.
4. Run the elevator up or down and adjust BRR so that the brake board has the output voltage equal to the BHV voltage setting.
5. Adjust brake per manufacturer specifications.

**Note:** *Use both Manufacturer's setup procedure and Table F for electrical and mechanical setting of the brake.*



**Brake Steps**

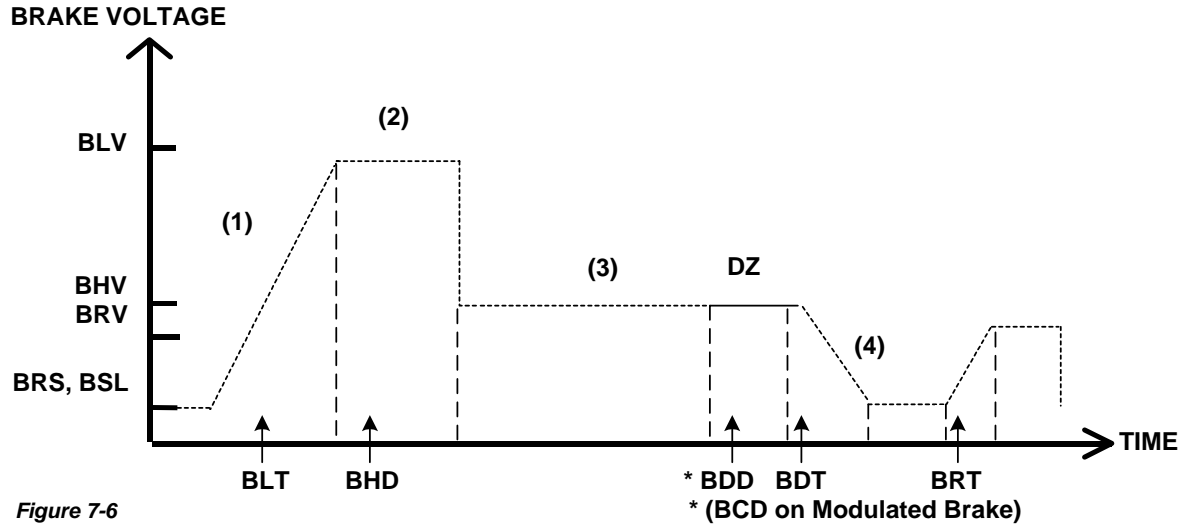

Figure 7-6

Adjustment Parameters			
Parameter	Range	Units	Description of Car Adjustment Parameters
BMV	20-500	VOLTS	Brake Maximum line Voltage. - AC line voltage applied to the Brake board.
BMA	1-20	AMPS	Brake Maximum Amps. - Maximum Amps used by the brake.
BLV	10-500	VOLTS	Brake Lift Voltage. - Initial Brake voltage. Maximum value is 90% of the Brake Maximum Voltage (BMV) parameter.
BHV	0-500	VOLTS	Brake Hold Voltage. - Brake voltage when the car is running.
BLT	0-320	1/64 SEC	Brake Lift Time. - Amount of time from Brake Start Lift (BSL) voltage to Brake Lift Voltage (BLV).
BHD	0-320	1/64 SEC	Brake Hold Delay. - Amount of time from when brake voltage reaches Brake Lift Voltage (BLV) until voltage is lowered to BHV value.
BSL	0-100	VOLTS	Brake Start Lift voltage. - The brake voltage output to the brake when a run is initiated.
BRV	1-500	VOLTS	Brake Re-level Voltage. - Lift voltage during a re-level.
BRT	0-320	1/64 SEC	Brake Re-level lift Time. - The amount of time from the Brake Re-level Start voltage (BRS) to the Brake Re-level Lift Voltage (BRV).
BRS	0-500	VOLTS	Brake Re-level Start lift Voltage. - The voltage output to the brake when a re-level is initiated.
BDD	0-320	1/64 SEC	Brake Drop Delay. - Time delay after the 2" (5 cm) door zone Brake voltage is reduced to zero volts.
BDT	0-320	1/64 SEC	Brake Drop Time. - The rate at which the brake voltage is reduced to zero volts.
BRR	0-65535	NUMERIC	Brake Regulator Resistance - Brake Board scaling factor

Table F

Note: BDD and BDT will be set up after the car is H.S.



**CCU Communications**

1. If using the CCU, at the Main Menu select **Car Commands** and press <ENTER>.

```
>Car Commands
Car Hoistway
Car Parameters
Car Status
```

2. Scroll down to the **CMC** Command and press <ENTER>. This will allow you to check the communication status to each board.

```
ASU      BAS
BBT      BDC
BIT      CCT
>CMC     CMG
```

3. Verify that each board is communicating. [See sample screens in the CCU usage appendix.]

```
HI  ST  RCV  FAIL  %F
3   OK  82   0    0
```

4. Scroll down through each board. If the board has input and output boards, use the ◀▶ arrow keys to check them.

**Note:** See *Car Commands* for more information regarding the CMC.

**Slowdown Switch Check**

1. On the CCU, at the Main Menu, select **Car I/Os** and press <ENTER>.

```
Car Hoistway
Car Parameters
Car Status
>Car I/Os
```

2. Set **Port** to **VIC** using the ◀▶ keys.

```
I/O Display
>port:  VIC
board:#0 SDM
type:  INPUT
```

3. Set **Board** to **SDM** using the ◀▶ keys.

```
I/O Display
port:  VIC
>board:#0 SDM
type:  INPUT
```

4. Run the car to both terminal landings and verify that the slowdowns and normal limits break in the correct order.  
(Example: SU2 – 1<sup>st</sup>; SU1 – 2<sup>nd</sup>; UNL – 3<sup>rd</sup>)
5. If the switches do not break in the correct order, go back and see that the car is breaking switches as necessary.

**Selector and ETS Check**

1. On the CCU, at the Main Menu, select **Car Status** and press <ENTER>.

```
Car Commands
Car Hoistway
Car Parameters
>Car Status
```

2. Using the ◀▶ keys scroll to **CTC** screen.

```
Ctc  Cm_  Ofpm_Dz
ETS U___ D___ Ef
Ulz  Ufz  Dfz  Dlz
Load  0%  0.0V
```

3. Run the car to both terminal landings and verify that the required ETS vanes turn on as floor level is reached.
4. While running the car in the up direction and passing an intermediate floor vane, verify that ULZ, UFZ, DFZ, and DLZ turn on then turn off in the correct order.

**Car Position Encoder Test**

1. Using the ◀▶ keys, change the display screen to the **CPE** display.

```
CPE  Cm_  Mem
Dpp  1001 Prx Af
Aud  Flv  Doe  Dos
Ncu  Sys  Esd  Est
```

2. Run the car in the up direction and verify direction arrow is up and DPP is counting up.
3. Run the car in the down direction and verify direction arrow is down and DPP is counting down.



**Note:** If either the arrow or the count direction is wrong, swap B and  $\bar{B}$  coming from the car top encoder at the top of car terminal strip.

**Note:** If on a tape application, swap DPP1 and DPP2 sensor wiring at CTI Board located in the Selector box.

- Rotate the display screen to main display using the ◀▶ keys.

```
INS Pos 4 0
VEL 0 0 0
DPP 1000 1000 276
[-] cc[] uc[] dc[] nu[]
```

- Run the car in both directions and verify DPP increases when running up and decreases when running down.

**Note:** If the count is counting in reverse, swap the DP1 and DP1/ coming to the CCU Plug P2.

- Verify car speed is equal to Demand speed (SR) using a handheld tachometer. If it is not equal, change the F-11 Motor RPM.
- Verify the displayed speed (Vel) is equal to the Demand speed (SR) within +/- 2 FPM in both directions. If not within tolerance, adjust the DPF parameter until SR and Vel are within +/- 2 FPM of each other.
- Rotate to VIC display and verify direction and speed are correct. If direction is incorrect, swap B and  $\bar{B}$  at the CCU encoder plug (P11). If speed is incorrect, adjust the RPM parameter in the **Car Control** submenu to match that of the F-11 Motor RPM.

**Note:** If using the wizard program, some of the above steps will not be necessary. You may view the different boards and displays via the diagnostic screens.

### Drive Parameters

Verify the drive parameters are setup per prints.

### Auto Setup (Hatch Scan)

- Run the car so it is approximately 1-2 ft. above the first opening.
- Go to the Main Menu on the CCU and select **Car Parameters** and press <ENTER>.

```
Car Commands
Car Hoistway
>Car Parameters
Car Status
```

- Scroll to **Vel** and press <ENTER>.
- Scroll to **IVE** and enter 20 FPM.
- Return to the Main Menu by pressing <MENU>.
- Select **Car Commands** and press <ENTER>.

```
>Car Commands
Car Hoistway
Car Parameters
Car Status
```

- Scroll to **ASU** and press <ENTER>.
- Using the panel run buttons, run the car down. It will stop past the bottom floor with just ULZ and UFZ activated.

**Note:** You may have to jump out bottom final.

- Next run the car up until the car stops past the top floor.

**Note:** If the elevator is stopped prior to reaching the top floor, the Auto Setup will be invalid and have to be done again.

**Note:** If using the Wizard, verify the position is advancing to the next floor as you run car up the hoistway.

- Once the car has stopped above the top landing, return to the Main Menu by pressing <MENU> button.
- Scroll to **Car Hoistway** and press <ENTER>.
- Scroll to **COT** and press <ENTER>.
- Verify that the Center of Target has values that are different than default values of 1000, 1400, 1800, etc...



- Verify parameters EUR, EDR, DLR and ULR under **Car Hoistway** submenu also have values different than the default. Verify the TSV, ESV and ETV settings are still set to those installed in step 4 of the Machine Room Verification on page 6-6.

**Note:** *If any of the above values are set to zero, insert a value that is approximately equal to where the switch is located in the hoistway.*

- If these parameters all have values, return to the Main Menu and select **Car Commands** by pressing <ENTER>.
- Scroll to the **WRT** command and press <ENTER>.
- Run the car down away from the top terminal floor using the DN button.

**Preparation for Running High Speed**

- Go to the Main Menu in the CCU.
- Scroll to **Car Control** and press <ENTER>.

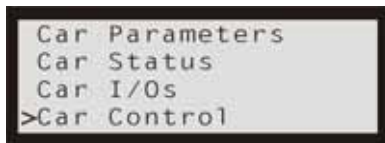

- Scroll to **Door Disconnect** and press <ENTER> to remove doors from operation.
- Scroll to **Pos** and increase FDZ parameter to 10.

**Note:** *FDZ is only required when using rail or governor encoder.*

- Use BIT command and set Bit 11 of Control Status Word 10 to turn on DPP count update.
- For Tape Selector applications, use the BIT command to set the Bit10 of Control Status Word 10 to turn on selector leveling sensors.

**Relevel Test**

- Press <MENU> button until you get to the display window. Use the ◀▶ keys to scroll to the CTC display.

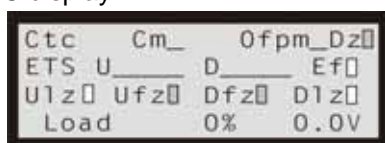

- Run the car UP or DN until you get ULZ or DLZ to go high.

- Turn the inspection switch to off to allow the car to go into automatic. Verify the car levels into floor level.
- Turn the car back to inspection mode and run car so the other leveling sensor is high and repeat step 3.

**One Floor Run**

- Go to the Main Menu in CCU.
- Scroll to **Car Commands** and press <ENTER>.
- Using the STD and STU commands run the car up and down one floor at a time. Verify the car will come into floor level and stop without overshooting the floor level.

**Note:** *You may have to make some temporary adjustments to the S-Curve to achieve this. If FDZ is too low, it may cause excessive relevels.*

**Preset "S" Curves**

- Verify a balanced load is on the elevator.
- Choose one of the S-Curve speed profiles provided using the SPD command.
  - Profile 1 = Fast
  - Profile 2 = Moderate
  - Profile 3 = Smooth

**Note:** You may manually set up the S-Curve profile by entering individual values for the S-Curve. See S-Curve Profile Table F. It is better to start out with a smoother ride Profile while tuning the drive.

**Obtaining High Speed**

- Once the car is able to make controlled stops at each floor, scroll to the SCC command and start to make Multi-Floor runs.
- Verify the car will come to a controlled stop after each run.
- Once we have reached the point where the controller is demanding High Speed on a run and the car comes to a controlled stop, make long runs avoiding the terminal floors.

**Note:** *Demand speed may be viewed using the Main display screen.*



4. During a High Speed run verify the speed of the car using a handheld tachometer. To change the speed of car, raise or lower the Motor Speed in the drive Function 11 (F11) parameter list. (Refer to Page 3-9 Quick Reference Chart.)
5. Verify the displayed car speed is within 1-2 FPM of the demand speed. Raise or lower Parameter DPF to correct any speed deviations at High Speed. DPF is in the POS submenu.
6. Go to the display screen and scroll to the **VIC** display using the ◀▶ keys.



7. Verify the VIC displays the correct car speed. To change the VIC display, change the RPM setting in the Control submenu to a value equal to the Motor Speed (F11) setting of the drive. (Refer to Page 3-10 Quick Reference Chart.)

**DSD 412 Final Adjustments**

1. Remove any weights from the car.
2. Place the car on Machine Room Inspection.
3. Verify the motor data and the parameters in the drive are in agreement.
4. From the CCU Main Menu select **Car Parameters**.
5. Scroll to **VEL** and press <ENTER>.
6. Scroll to **IVE** and press <ENTER>.
7. Set **IVE** to 10 and press <ENTER>.
8. Start with parameter 40 on the SCR drive at a value of 7.
9. From the panel test buttons at the controller press the down direction button monitoring the drive sheave.  
  
Note the amount of up rollback.
10. Increase the drive parameter 41 (System Inertia) until there is very little rollback.

**Note:** Some rollback is required.

11. Set the **IVE** parameter to 50 and run the elevator up and down.
12. Observe the machine for any vibrations.
13. Should vibration exist lower the SCR drive parameter 40 (Response) until the vibration is eliminated.
14. Take the car off Machine Room Inspection and make high speed runs up and down.

**Note:** Should a 407 fault appear on the drive, Lower your motor field weakening value (49) and possibly Field Weaken Speed (57) until the 407 is just eliminated. Verify Armature voltage (610) is just below nameplate in the Down direction, Empty car. [See DSD 412 Manual for Fault Descriptions.]

15. Should the car have any vibration at high speed use the following to set the Reduced Gain:
  - A. Using the SDCU scroll to parameter **104**.
  - B. Set **104** to the OFF position and press <ENTER>.
  - C. Scroll to **105** and press <Data> Key. Note this value.
  - D. Set **105** to a % of high Speed you wish to start reducing the gain. (start at .80) and press <ENTER>. (105 should be set to a speed just prior to the start of the vibration)
  - E. Scroll to parameter **108** and press <Data> Key. Note this value.
  - F. Set **108** to the % of Gain desired when reduce gain is requested. (start at .70) and press <ENTER>. (108 should be set just low enough to eliminate the vibration)
  - G. Continue running high speed up and down and adjust **105** and **108** for the best ride quality possible.

**Note:** The gain and speed reduction should never be taken under .50. Should the vibration continue check for possible other cause, possibly mechanical.



15. Using the SDCU on the drive, scroll to parameter **994** and save the new settings. (Refer to "Saving Drive Parameters" on page 3-8.)
16. Return to "Running High Speed" in the Meridia Adjustment Procedures.

**Observing the 'S' Curve on the Drive (DSD 412)  
(OPTIONAL)**

**Note:** A dual channel storage scope is required to view the speed command and speed feedback.

1. Set the 'O' scope to storage, 2 channels with a .5-second per division sweep.
2. Place Channel one probe to Test Point TP41 (Speed Reference) with the ground clip to TP47 (Common).
3. Place Channel two probe to Test Point TP44 (Speed Feedback) with the ground clip to TP47 (Common).
4. Verify P95 on the drive is set to 0 for Speed Reference.
5. Verify P96 on the drive is set to 0 for Speed Feedback.
6. Set the Probe Voltage to a setting to allow the 'S' curve to be completely shown on the screen. (10 Volt output at high speed.)

**Note:** To view final approach a lower voltage setting around .2V/Div may be used.

7. Adjust the 'S' curve parameter until a stable final approach is achieved.

**Note:** With both traces set on the same division line prior to a run, a stable approach will have the speed feedback merging and following speed command during the LVE portion of the final approach.

**Note:** If the speed feedback crosses and goes below the speed command, the drive's response may be set too low.

**Initial O'scope Setting:**

STORAGE      10V/div.  
                  5sec./div.

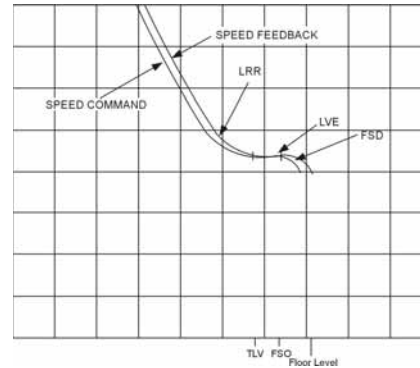

**Figure 7-7**

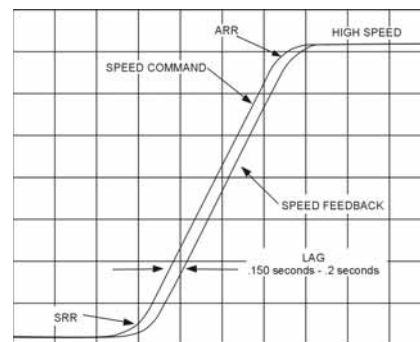

**Figure 7-8**

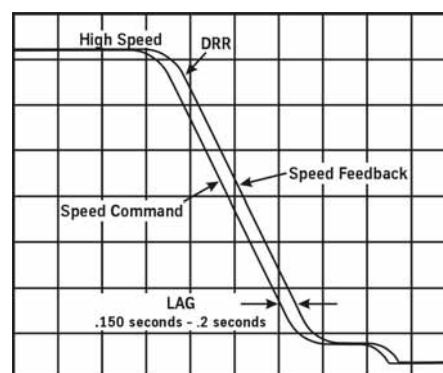

**Figure 7-9**

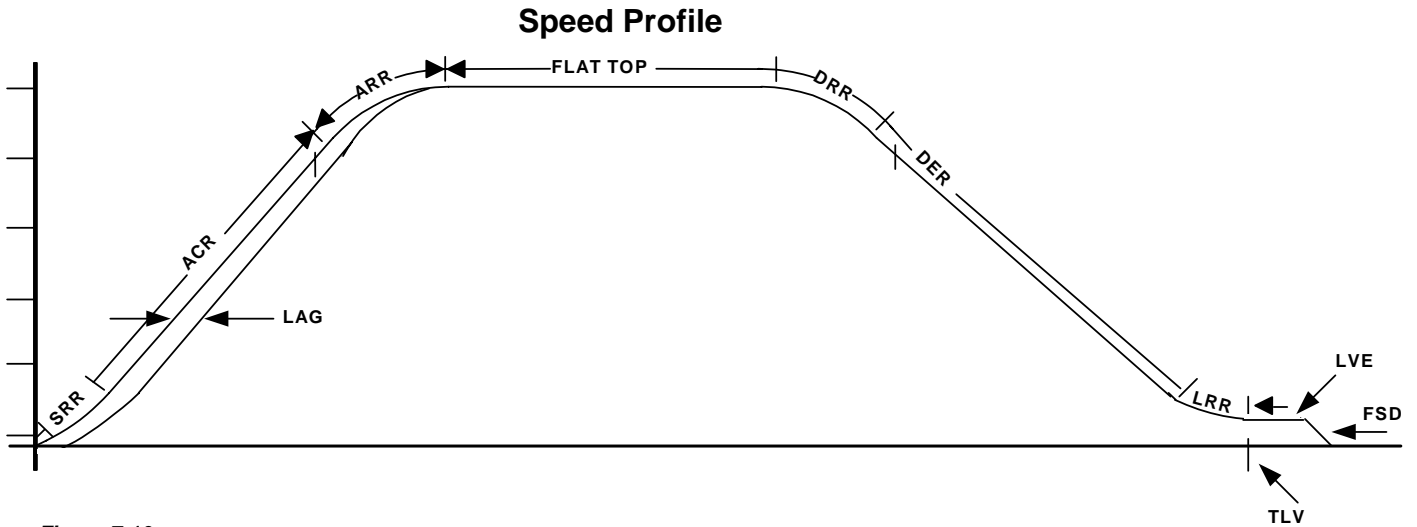

Figure 7-10

Parameter	Range	Default	Units	Description of Car Adjustment Parameters
FSD	0-24	0	1/64 sec	Final Stop Damping. Velocity Damping during the final stop. The damping time represents the number of samples that are averaged every 1/64 second. On final stop, the demand velocity is changed from the leveling velocity to zero instantly. Having a damping of 8 would cause the velocity to slope down from the leveling velocity to zero in 1/8 second (8/64).
FDZ	1-32	5	DPP	Floor Dead Zone: The number of counts the car must go out of dead level to cause the car to re-level. (In DPP counts)
FSO	0-26	3	DPP	Floor Stop Offset: Number of counts prior to reaching the floor dead level position that a stop sequence begins for a normal run. (In DPP counts)
DER	80-300	150	F/ms	Deceleration Rate: The rate of Constant Deceleration of the car to the transfer to leveling. Divide DER by 60 to convert to feet per second. (or multiply DER by 0.00508 to convert to m/s <sup>2</sup> ).
DRR	1-480	250	F/ms <sup>2</sup>	Decel Roll Rate: The rate in which the car rolls into Constant Deceleration from Top Speed.
ACR	75-300	150	F/ms	Acceleration Rate: The rate of constant acceleration for the car to top speed. Divide ACR parameter by 60 to convert value into feet-per-second. (multiply ACR by 0.00508 to convert to m/s <sup>2</sup> )
ARR	1-480	250	F/ms <sup>2</sup>	Acceleration Roll Rate into top speed.
LAG	1-320	0	1/64 sec	Car LAG compensation
LRR	1-480	250	F/ms <sup>2</sup>	Leveling Roll Rate into leveling speed.
LVE	1-20	8	F/m	Leveling VELOCITY (feet per minute).
RSO	0-20	4	DPP	Floor Re-level Stop Offset: Number of counts prior to reaching the floor dead level position that a stop sequence begins for a re-level. (In DPP counts)
SRR	1-480	250	F/ms <sup>2</sup>	Start Roll Rate from zero speed.
TLV	0-80	5	DPP	Transfer to Leveling Vane (DPP): Distance from floor level at which the constant leveling velocity takes effect. NOTE: When car enters the 2 inch Leveling Zone (5 cm), a constant leveling velocity is introduced.

Table G



8. Once the car is leveling and stopping correctly with a balanced load, use full load and empty load to verify the car stops and starts throughout the load range.
  - A. You may have to increase the response of the drive so the car will level with the full load.
  - B. Verify the car does not have rollback when full or empty load is on the car. Use BLT, BLV, BSL, and SRR to achieve good starts.

### Floor Accuracy Adjustments

1. Place balanced load on the elevator.
2. If using the encoder leveling system (no tape), verify that FDZ is set to minimize relevels.

**Note:** To calculate the dead zone, use the following formula:

$$\left(\frac{DPF}{10}\right) \div 12 = \text{Pulse Per Inch}$$

For 1/4" Dead zone and DPF of 2552, FDZ would equal approximately 5.

3. Run the car to each floor and check the Floor accuracy in both directions.
  - A. If the car is stopping high, counts will need to be removed.
  - B. If the car is stopping low, counts will need to be added.
4. To add or remove counts, change the FOF settings in the **Car Hoistway** submenu.
  - A. To change counts, scroll to the desired floor and press <ENTER>.
  - B. Use the ▲ key to add counts or the ▼ key to remove the desired counts then press <ENTER>.

**Note:** FOF1 = the first opening;  
FOF2 = the second opening; etc...  
Care should be taken to change the correct floor.

**Note:** If using the Wizard Program, to change floor levels use the following for an example:

FOF3 = + 7    To add count  
FOF5 = 0 - 3    To remove count

**Note:** The maximum amount of offset is 10. If you need to increase more than 10 you will have to move the leveling vane and then do a new Hatch Scan.

5. Repeat steps 3 and 4 for each floor.
6. If using a tape and magnets for leveling, set the ULZ and DLZ sensors for the desired dead zone.
7. Set FSO to 1.
8. To change the floor level accuracy, you will have to move the 12" leveling magnet to get the car to stop at floor level.

**Note:** If Magnets are moved more than 3/8 of an inch, a new Hatch Scan should be done.

9. Once the floor offsets have been entered, go to the **Car Commands** at the CCU and press <ENTER>.
10. Then scroll to **WRT** command and press <ENTER> to store all changes.

### Terminal Backup Setup and Tests

#### Terminal Backup using the CCU

**Note:** Proceed to the Appendix for a sample of the Terminal Backup Case Chart. Table B, C, and D are referred to in these steps.

1. Set the **LPE** Parameter in the **Pos** parameter submenu to 1000.
2. Verify Bit 11 of the Control Status Word C10 is set using the BIT command in the Car Command submenu.
3. In the **Car Hoistway** submenu, verify the ETV, ESV, and TSV values are set high so the car will not fault out.

**Note:** Refer to Machine Room verification for the values.

4. Run the car into the top terminal floor at high speed. After the car stops, go to the **Car Hoistway** submenu and record the top terminal positions in Table B (of the appendix) by entering the ULB and EUB commands.



5. Run the car into the bottom terminal floor at high speeds. After the car stops, go to the **Car Hoistway** submenu and record the bottom terminal position and velocity in Table C (of the appendix) by entering the DLB and EDB commands.
6. After both the top and bottom distances have been recorded, calculate the distance from the floor level and record in Table B and C (of the appendix).
  - A. If switches or vanes are not within 3 inches of each other, move either the top or bottom switch or vane to correct.
  - B. If switches or vanes needed to be moved, repeat steps 4 – 6 until switches and vanes are in the correct location.
7. If the learned values are within 3” of each other, enter these learned values in their corresponding references. The reference values are located under the **Car Hoistway** submenu.  
  
 Example:   ULR1 = 22568  
               EUR = 22731
8. After switches are in their correct location and reference set, run the car into the top and bottom terminal floors. When the car stops, go to the **Car Hoistway** submenu and enter the appropriate commands listed in Table D (of the appendix). Record the data in table.
9. After all data is recorded, verify up and down speeds are within +/- 5 of each other.
10. In the Car Hoistway submenu, enter the TSV, ETV, and ESV values from the table.
11. Set LPE to a value of 6”.  
        $LPE = (DPF \div 20)$
12. Run the car into both top and bottom terminals using multifloor runs and verify that there are no errors.

13. In the **Car Commands** submenu, scroll to **WRT** command and press <ENTER> to save all new values.



**Note:** *If using the Wizard program, the limit velocities and positions are accessed with different commands. See Table H.*

CCU	Wizard
ULB	ULB
EUB	ELB
DLB	DLB
EDB	ELB
TUB	ULB
TDB	DLB
ETB	ELB
ESB	Not Used

Note:  $ESV = TSV + 10 \text{ FPM}$   
 Therefore if TSV1 equals 178,  
 ESV1 equals 188

**Table H**



### Load Weigher Setup

**Note:** *This procedure is only for the CEC proximity sensor.*

1. Place the elevator with no load at the bottom landing on car top inspection.
2. Using a voltmeter on the DC scale, connect the positive lead on LW2 and the negative lead on GND in the CTC. [See Figure 1-37.]
3. For crosshead mounted sensor, adjust the sensor until the voltmeter measures +1.0 to +1.4 Volts DC
4. For Isolated platform mount sensor the voltage will be between +4.2 and +4.6 VDC.
5. Lock the sensor in place with the lock nut.
6. Place the car on Independent Service.
7. Using the CCU select **Car Commands**.
8. Scroll down to the **LWU** command and press <ENTER>.
9. Select the **Proximity Sensor Setup** and press <ENTER>.
10. Select the installation type (either Cross head mount or under platform) and press <ENTER>.
11. With the car empty at the bottom floor, select **LWU1** and press <ENTER>.
12. Once the display shows **LWU1 OK**, press <ENTER>.
13. Place full load on the elevator.
14. Select **LWU2** and press <ENTER>.
15. Once the display shows **LWU2 OK**, press <ENTER>.
16. From inside the elevator, run the fully loaded car on Independent to the top floor.
17. Select **LWU3** and press <ENTER>.
18. Once the display shows **LWU3 OK**, press <ENTER>.
19. Remove all weights from inside the elevator.
20. Select **LWU4** and press <ENTER>.
21. Once the display shows **LWU4 OK**, press <ENTER>.

22. Press <ENTER> to scroll to the **WRT** command and press <ENTER> to save these readings.
23. Scroll to **LWU** and press <ENTER>.
24. Select **Activation Offset Calibration** and press <ENTER>.
25. Scroll to the **WRT** Command and press <ENTER> to save the new parameters.
26. Press <MENU> twice to return to the Main Menu

### Setting Pre-torque

1. Place an empty car at the top floor.
2. Set the following CSW bits:  
  
CS3 bit 7 CS8 bit 9 CS9 bit 11
3. Set car parameter BAL to the % amount the car is counterweighted. This is usually 40% to 45%.
4. Set car parameter PDT to 24.
5. Set SRR car parameter to a value that will cause the car to roll back 1" before accelerating.
6. Increase car parameter TLC in increments of 500 until no roll back is present.
7. Scroll to the WRT Command and press ENTER to save the new parameters.



**Additional Parameter Adjustments**

1. Scroll to the **Car Parameters** and press <ENTER>.
2. Scroll to **Vel** and press <ENTER>.
3. Set the following parameters. See Table I.

VEE	Highest difference between Speed Reference and Velocity during Acceleration plus 30.
MLV	150 (FPM)
MRV	60 (FPM)

*Table I*

4. Press the <MENU> button to return to the **Car Parameter** sub-menu.

CDL	DPP position count of the elevator when the platform is even with the top of the counter-weight. <b>Only if CWT derailment is required.</b>
CDH	DPP position count of the elevator when the crosshead is even with the bottom of the counter-weight. <b>Only if CWT derailment is required.</b>

*Table J*

**Miscellaneous Adjustments**

**Setting the Hoistway Access**

1. Place the car at the top floor on Inspection (ICA)

2. Set parameters ACT to a value to stop the car to a preferred level.

**Note:** ACT and ACB values are not used until the car travels off of SD1 or SU1.

3. Access car down verifying car stops where desired.
4. Repeat at bottom floor setting ACB.

**NOTE** If top access is located other than top floor, set ACF to the Top Access Floor

**Setting Earthquake Collision (If required)**

1. Run the car on inspection 1-2' below the point where the bottom of the counterweight would strike the car.
2. Record the DPC count.
3. Set CDL to the value recorded in step 2.
4. Run the car up 1-2' beyond the point where the bottom of the car would strike the counterweight.
5. Record the DPC count.
6. Set CDH to the value recorded in step 5.
7. Enter the WRT command.



**Various Door Parameters and Control Status Word Settings**

<b>DOORS</b>			
<b>CSn</b>	<b>Bit</b>	<b>DEFAULT</b>	<b>DESCRIPTION</b>
0	13	R	When set and on independent service, the doors will close automatically when a car call is registered.
1	4	R	When set, pre-opening is disabled for the front doors.
1	5	R	When set, front door pre-opening will occur at the 2" leveling zone.
2	1	R	If set, pressing the door close button shortens the door open time. If reset, DCB has no affect on door open time.
2	8	R	If set, does not allow reopening of doors with the safety edge or the electric eye during nudging.
3	13	R	If set, door-nudging operation is disabled.
4	5	R	If set, front door pre-opening will occur when car reaches 6" from floor level.
5	3	R	If set, car will shutdown if car goes out of the level zone and doors are open.
<b>CSn</b>	<b>Bit</b>	<b>DEFAULT</b>	<b>DESCRIPTION</b>
6	3	R	Set to disable electronic detector edge time out.
6	4	R	Set to enable electronic detector edge operation Vs. mechanical safety edge.
6	5	R	Set to enable electronic proximity edge operation Vs. mechanical safety edge.
6	14	R	Set to enable drive fault GLR error. (both GLR input and DOL input active while at the floor)
7	10	R	Set to invert detector edge input.
9	5	R	Set to require DCL on (with GLI and GL) to start car.

<b>DOORS</b>			
<b>PAR</b>	<b>RANGE</b>	<b>UNIT</b>	<b>DESCRIPTION</b>
CDT	16-200	1/16s	Door Open Time: Time for doors after answering a car call.
DCC	2-20	Units	Door Cycle protection Counter: Normally adjusted for 6 cycles before removing power form doors.
DCP	5-20	Sec.	Door Close Protection time: The amount of time the doors are given to close before taken out of service on door protect.
DDT	0-80	Sec.	Door open Time after activation of DOB input.
DHT	0-64	1/16s	Door Hold Time: Delay time before high-speed door opening. Only used on Dover OHS door operator circuits.
DOH	0-360	Sec.	Extra Door Open button Hold time: Only used with door hold buttons.
DOP	5-20	Sec.	Door Open Protective time: Amount of time allowed to open the doors before taken out of service on door protects
DOT	0-60	Sec.	Door Open button Time-out: Maximum amount of time doors are allowed to remain open form the door open input.
LDT	32-200	1/16s	Long Door open Time: Time used when car answers a hall call.
NDT	5-120	Sec.	Nudging Door Time: Time doors are allowed to be held open before nudging goes into effect.
SDT	4-48	1/16s	Short Door Time: Door time after electric eye or safety edge has been activated.



FIRE			
PAR	RANGE	UNIT	DESCRIPTION
FAL	1-# FLs	Unit	Fire recall Alternate Floor: The alternate floor to which car recalls when main fire floor sensor is activated.
FBT	1-65535	1/64s	Fire Bypass Timer for GSA fire standard.
FIR	1-# FLs	Unit	Fire Recall Floor: The main fire floor for phase 1 recall mode.
IFT	0-300	Sec.	Independent Fire Time: Time system takes to override independent service during fire phase 1 operation.

FIRE			
CSn	Bit	DEFAULT	DESCRIPTION
1	8	R	When set, the fire buzzer is pulsed.
1	9	R	When set, the fire emergency light is pulsed.
1	10	R	When set, the stop switch is not bypassed. When reset, it is bypassed according to bit 11.
1	11	R	When set, stop switch is bypassed all the time. When reset, the stopswitch is bypassed according to ANSI code standard.
1	13	R	When set, the in-car fire service light also operates during phase II.
CSn	Bit	DEFAULT	DESCRIPTION
1	14	R	When set, the doors will close when a car call is registered. If reset, the door must be closed with the door close button.
3	3	R	If set, allows car to shut automatically after phase II key switch is set to "OFF" and phase I condition exists.
3	5	R	When set, the door open button is disabled during phase I fire service.
3	14	R	If set, door-nudging operation is activated during phase I fire service operation while the door is closing. <b>This bit will override bit 13 (disable nudging).</b>
4	0	R	If reset, car will open front door automatically when it reaches the fire floor during phase I.

CALL			
CSn	Bit	DEFAULT	DESCRIPTION
0	4	R	If set, dumps all calls after consecutive car calls answered per CCD parameter number order with no electric eye break.
4	10	R	If set, car calls will not be cancelled when the car has a reversal slowdown.
4	11	R	If set, cancel car calls for positions above the car when the car is moving down and cancel car calls below the car when the car is moving up.
7	15	R	Set to pulse car call output for low intensity lights.



**Buffer Test**

1. Place the car two floors above the bottom floor (for car buffer test) or two floors below the top floor (for a Counterweight buffer test).

**Note:** For the Car Buffer, place a full load on the car.

2. Record the values for the following parameters: ETV, ESV, TSV, LPE and VEE.
3. Set the following parameters to their new Temporary values:  
ETV, ESV and TSV = CONTRACT SPEED,  
VEE=300, LPE=1000.
4. Install the following Temporary jumpers to bypass:

FROM	TO	DESCRIPTION
SD1	SU1	Closest terminal slowdown*
UNL	DNL	Directional limits
HS	CS	Disable emergency inputs on car top.
LCS	HS	Final Limits (if required by local code.)

\* Other SU\_ and SD\_ slowdown switches will need to be jumper if provided.

5. Enter BITS0,1 so the DPC count is not updated when the car starts.
6. Set DPC to equal the COT value for the next floor above the car for a car buffer test or next floor below for a counterweight buffer test.
7. Enter SCC1 for the car to run down to the car buffer or enter SCC<sub>n</sub> the top floor for the car to past the top floor for the counterweight buffer.
8. When the buffer is hit by the car or counterweight place the car on Panel test in the machine room.
9. Lift the car or counterweight off the buffer by running the car on Machine room inspection.
10. Repeat for the other buffer.

**Note:** Remove the weight for CWT buffer.

**Note:** If using reduced speed buffers, lower high speed using MMS parameter and set BIT 5 of CS7.



**Over Speed Test**

1. Run fully loaded car at the top floor.
2. Record the values in the drive for the encoder pulses per revolution. DSD 412 is Parameter 10.
3. Record original value for VEE and temporarily set it to 300.
4. Divide the value recorded in Step 2 by the contract speed of the elevator. This will give you the pulses per foot of speed. Record this value.
5. Check the governor data tag for the proper switch speed and safety activation speed.
6. Multiply the switch speed with the value recorded in step 4. This will give you the new Encoder value to enter into the drive to run the car at switch trip speed.
7. Place this new value into Parameter 10 of the DSD 412.
8. If required, place a jumper from **LCS** to **GV** to bypass the safety switch.
9. Place a call one floor above the bottom landing. The car should accelerate normally to the switch trip speed and activate the switch.

**Note:** *The Encoder value may need to have further adjustment to obtain the desired speed.*

10. After switch over speed test is complete set the encoder value back to the original setting and run the car to the top floor.
11. Multiply the safety activation speed with the value recorded in step 4. This will give you the new Encoder Value for the safety activation speed.
12. Enter this new value from step 13 into the Encoder Value in the drive.
13. Place a temporary jumper from **LCS** to **GV** if not already installed.
14. Place a jumper from **HS** to **CS** if required by local codes to bypass the safety plank.
15. Have someone stand next to the disconnect and be ready to place the car on Machine room inspection.

16. Place a call for 1 floor above the bottom landing. The car will accelerate to a speed that will activate the car safeties.

**Note:** *Should a F407 appear on the drive, the motor field weakening value (P49) will have to be lowered by 30% and the field weaken speed (p57) set to 50.*

17. Once the safeties have been engaged and stopped the car the car should be placed on Machine room panel test.
18. Reset the drives encoder value to the original setting recorded in step 2.
19. Reset VEE to its original value recorded in step 3.
20. If required, reset the field weakening (P49) and Field weakening Speed (P57) value to their original values.
21. Remove all installed temporary jumpers.

**Note:** *It is recommended that the safeties be released by running the car in the up direction while under Inspection operation.*

