



SECTION 3 - MERIDIA STARTUP PROCEDURES With DSD 412

Machine Room Preparations

FIELD WIRING CHECK

1. Verify Mainline disconnect is in the off position and properly locked out.
2. Verify all the circuit breakers on the front panel (located at the top of the controller) are in the off position. [See Figure 3-1.]

Meridia Circuit Breakers

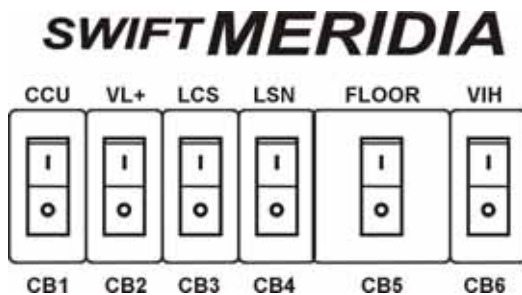

Figure 3-1

3. Turn the Inspection switch to the **ON** position.
4. Verify Door Bypass switches are in the **OFF** position.
5. Verify that the following field wires are connected as described in the Installation portion of this manual.
 - A. **Power wiring to the controller:** The power wiring can be a 2, 3 or 4 circuit configuration, depending on the drive system that is supplied.
 - 1) An independent, single-phase supply for the cab lighting circuit is the first circuit common to all drive types.



Warning! The MERIDIA controller transformer is not designed to support cab lighting and cab ventilation. Using the MERIDIA 120 VAC control circuits in this manner may cause permanent damage to the main controller transformer.

- 2) An independent, emergency backed, single-phase 120 VAC circuit is common to all drive types (for the first controller of each group only) [See Figure 3-2.]

Hall Call Power Circuit

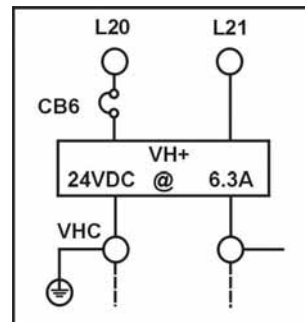

Figure 3-2

- 3) The 3-phase mainline power circuit is common to all drive types. The power connects to the primary side of an Isolation, Step UP or Step Down power transformer. The secondary side will be wired to the fuse block in the drive side of the controller. [See Figure 3-3.]

Three-Phase Power Circuit

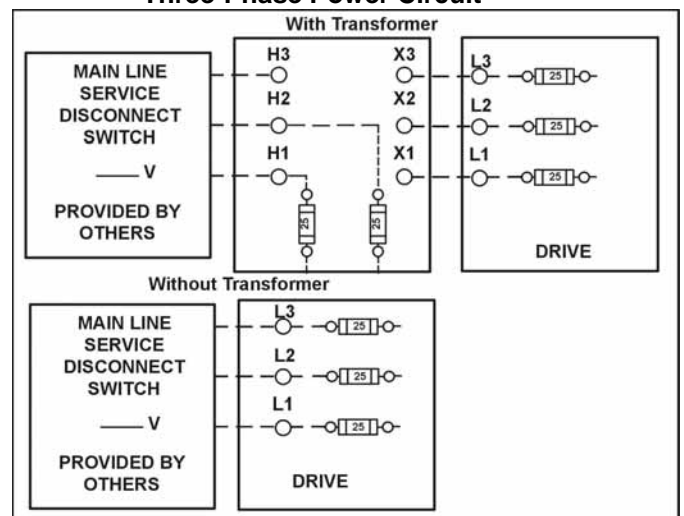

Figure 3-3



- The fourth circuit is a separate fused circuit from the primary side of the power transformer terminals L1 and L2 to the FP1 fuse block on the drive side of the controller. [See Figure 3-4.]

Controller Power Circuit

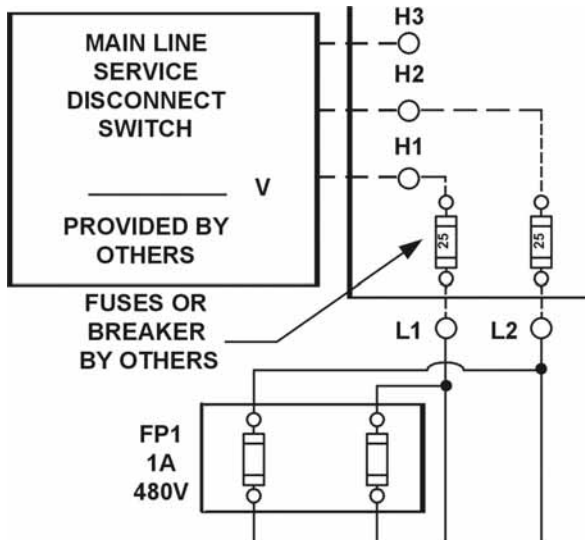

Figure 3-4

Note: All wire sizes are to be in accordance to the National Electrical Code.

Note: The main line power must supply a ground wire in accordance to National Electrical Code that is continuous to the source or to an earth ground connection.

B. Power wiring to the hoist machine:

There will be 2 to 4 circuits required to the elevator hoist machine.

- The first is to the motor that consists of current conductors wired from the drive output through the choke (if required) to the motor, and a ground wire to the grounding lug at the drive side of the controller. [See Figure 3-5.]

Motor Wiring

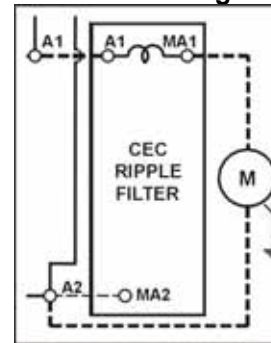

DC Application

Figure 3-5

- The second circuit provides power to the brake coil. These 2 wires can be run with the motor wires. [See Figure 3-6.]

Brake Wiring



Figure 3-6

- The third circuit is to bring power to the Motor Fields. These 2 wires can be run with the motor wires. Verify Dipswitches are set for proper Motor Field Current. [See Wiring Diagrams and Figure 3-7.]

Motor Field Wiring

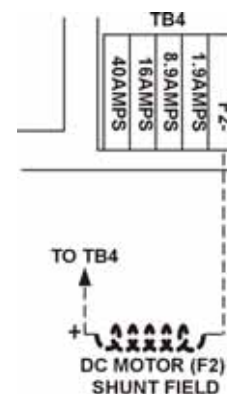

Figure 3-7

- The fourth circuit is for the brake switch (if required).



Motor Encoder Wiring: The encoder wiring uses 3 twisted shielded pairs. This cable is provided from CEC on most applications. See wiring diagrams for connections. It is imperative that this wiring be run separately from the encoder to the drive side of the controller and connected properly. [See Figure 3-8.]

Motor Encoder

	ENCODER TYPE						TERMINAL		
	SOLID SHAFT ALL	HOLLOW SHAFT 1024	10K	2500	4096	2500 10K	DSD 412	HPV 900	UNICO 1100
	DYNAPAR 17 PIN	DYNAPAR 10 PIN	BEI 7 PIN	BEI 10 PIN	LUCAS	LUCAS	TB1	TB1	CONN 2
5V	D	D	D	B	D	A	1	25	1
COM	F	F	F	A	G	C	43	19	2
A	A	A	A	D	F	B	2	21	3
Ā	C	H	C	G	H	E	3	20	4
B	B	B	B	E	B	D	4	23	5
Ī	E	I	E	H	A	F	5	22	6
SHLD							6	26	GND

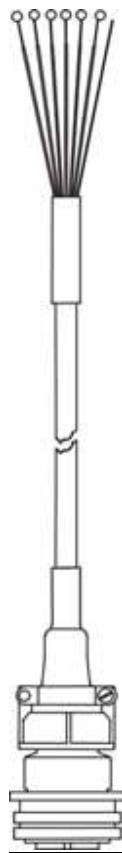

Figure 3-8

Governor Wiring two 18 gauge wires are required from the electrical safety switch on the governor to the controller. See [Figure 3-9.]

Governor Wiring

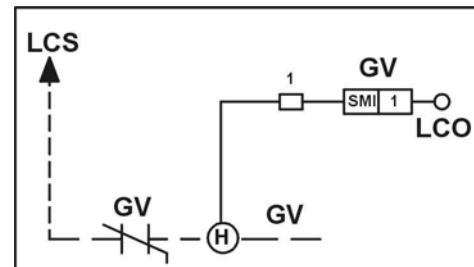

Figure 3-9

VERIFYING CIRCUIT RESISTANCES

1. Check the brake coil:
 - A. Disconnect the brake coil leads (BK- & BK+).
 - B. With an ohmmeter, measure the coil resistance and verify it matches the value given on the wiring diagram power distribution page. Note this value.
 - C. Next measure the brake coil leads to ground and verify that neither brake lead is grounded.
2. Disconnect Motor Field Leads. With an ohmmeter measure the motor leads at the controller to ensure the motor is not grounded. Record this value. Verify the motor field is wired in the proper configuration and the Dip Switch settings are correct on the A3 Motor Field. See Notes page on the wiring diagrams for details.



ISOLATION TRANSFORMER(S) CONFIGURATION (If required)

1. Verify the mainline voltage:
 - A. Measure and record the input voltage at the mainline disconnect.
 - B. Ensure the voltage agrees with the job voltage +/- 10%. See the Power Distribution page of the wiring diagrams.
2. On the isolation transformer, verify the data nameplate meets the actual job requirements for input and output voltages. See Power Distribution page of the wiring diagrams.
3. Verify all transformer taps are connected for proper voltage according to the Power Distribution page of the wiring diagrams.

CONTROLLER TRANSFORMER CONFIGURATION

1. Verify the wires from the FP1 fuses are connected to the proper taps on the controller transformer. This tap setting should be the same as the 3 phase voltage at the disconnect. [See Figure 3-10.]

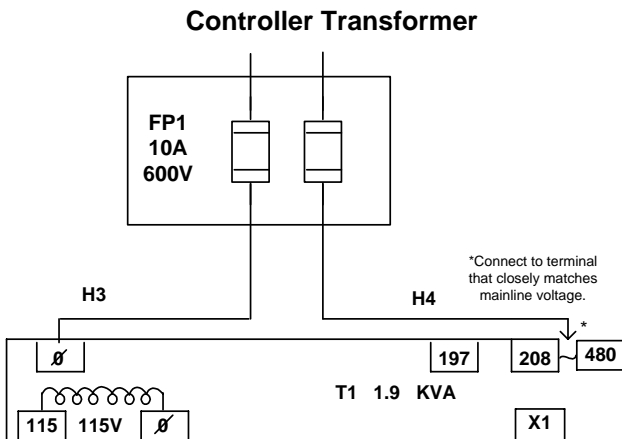

Figure 3-10

2. Verify the transformer configuration for the brake circuit. See wiring diagrams for details.
3. Verify the 115 VAC taps are configured correctly. [See wiring diagrams for details.]

CHOKO CONFIGURATION

Verify the motor armature wires are connected properly to the Choke Assembly and SCR drive. [See Figure 3-11 and Wiring Diagrams.]

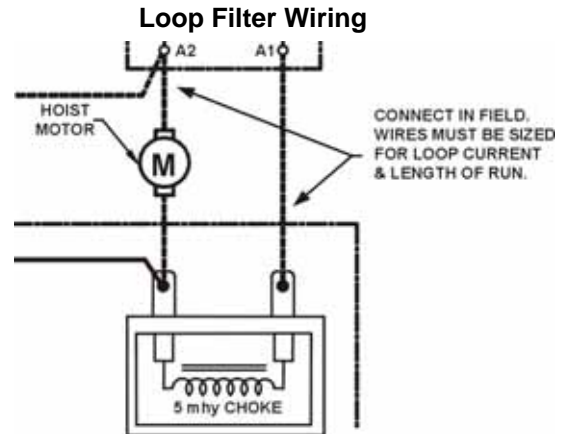

Figure 3-11

JUMPER CONFIGURATION

Install the following jumpers to bypass these circuits that may not be installed at this time. [See Table A.]

Temporary Jumpers					
Circuit	From	To	Circuit	From	To
UP Normal Limit	LCS	UNL	Car Gate	GLT	CG
DN Normal Limit	LCS	DNL	Front Locks	GLT	DL
Governor	LCS	GV	Group Power	V+	VG+
Hoistway Safeties	GV	HS	Group Common	VC	VGC
Car Safeties	HS	ICS	Normal Power	VG+	NP
Car Insp. Switches	ICS	II	Drive Switch	V+	DRVS
Rear Gate	GLT	RCG	Rear Locks	RDL	GLT
Panel test operation	TIC	TIA			

Table A

Warning!

These jumpers are only temporary and must be removed as the circuits are installed. Never operate a car at high speed with door and safety related circuit jumpers still installed.



AC VOLTAGE AND SWITCH TEST

1. With the controller circuit breakers off, turn on the mainline disconnect and verify the building 3 phase is within 10% of what is noted on the wiring diagrams.
2. Verify the Secondary voltage on the isolation transformer (if required) is within 10% of nameplate voltage.
3. Verify the proper voltage across the bottom of drive fuses F1 – F3. This voltage should be equal to the voltage recorded in Step 2 if a transformer is supplied or Step 1 if no transformer is supplied.
4. Verify that the voltages across the bottom of the FP1 fuses are the same as the building 3 phase voltage noted in Step 1.
5. Verify the primary voltage is within 10% at the T1 controller transformer located behind the logic door. See wiring diagrams for proper voltages.

CIRCUIT BREAKER & POWER VERIFICATION

1. Turn on CB3 and verify there is 115VAC between LCS & LCO.
2. Verify the drive is also powered UP.
3. Turn on CB4 and verify there is 115VAC between LSN & LCO.
4. Turn on CB5 and verify there is the proper voltage for the door operator. See wiring diagrams for details.
5. Turn on CB1 and verify the following.
 - A. The CCU V+ LED should be lit and the display active. Disregard any other LEDs.
6. Turn off all circuit breakers and mainline disconnect.

CCU POWER-UP, INITIALIZATION

1. With the mainline disconnect switch on, turn on CB1.
2. Verify the CCU front panel V+ LED stays lit green and display is active. [See Figure 3-13.]

Note: *First, the window will display the job number and the car number you are working on. Next, the window will display any Communication faults with the CCU devices. If the Car Top Box is not connected, a CTC fault will occur. Disregard any faults for devices that are not connected.*

3. Press the <MENU> key on the CCU for accessing password menu. [See Figure 3-12.]

CCU Key Pad

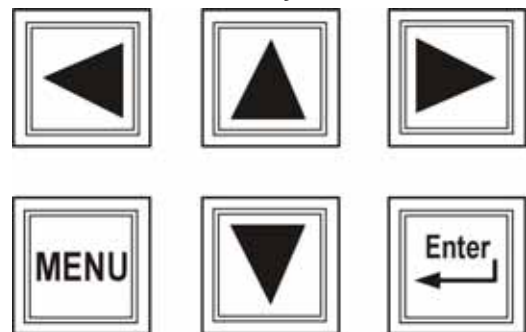

Figure 3-12

4. After reading the directions, enter the password "INSTALL" then press the <ENTER> key (the display should now show the main menu. If not, enter the password again).
 - A. Use the ▲▼ arrow keys to select the proper character. Starting with the ▼ (down) button will display the alphabetic characters first.
 - B. Use the ◀▶ arrow keys to move from one character to another.

Note: *Do not press <ENTER> after each character. Only press the <ENTER> key after the last character has been selected for the password.*



Display Menu (While Entering Password)

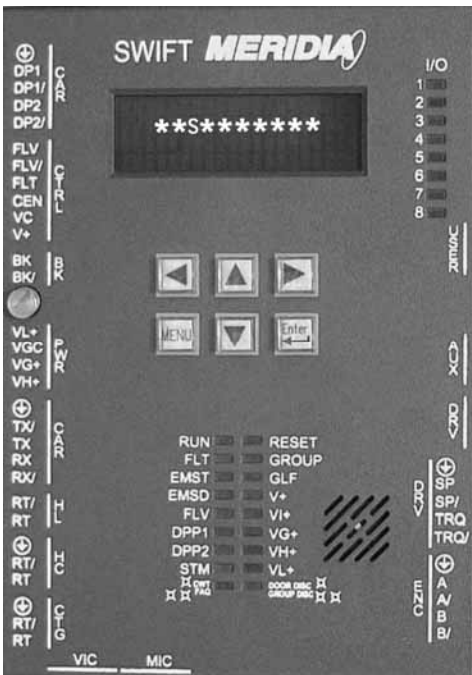

Figure 3-13

SETUP MODE AND WRT COMMAND

- Using the ▲▼ arrow keys scroll to **Car Control** and press <ENTER>.

Display Menu (While on Main Menu)

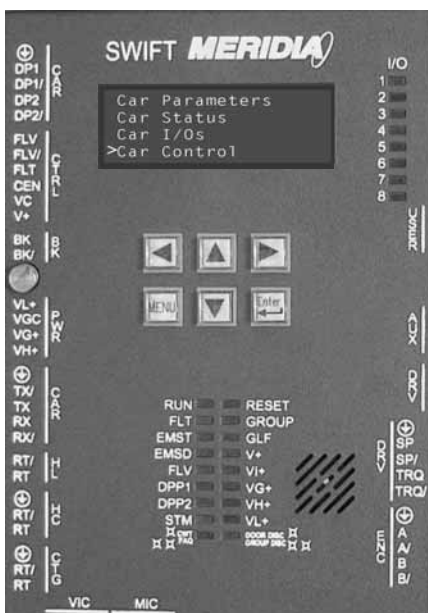

Figure 3-14

- Scroll down to **Set UP Mode Sel** (this mode allows you to move the car without the cartop devices installed) and press <ENTER>. This should start the STM LED to start flashing orange. [See Figure 3-15.]
- Press <MENU> button until you return to the Diagnostic Status Display.
- Verify CEN, DL and CG relays are energized.

Note: If CEN, DL and CG relays are not energized, check temporary jumpers and troubleshooting section of this manual.

Meridia CCU (While on Diagnostic Screen)

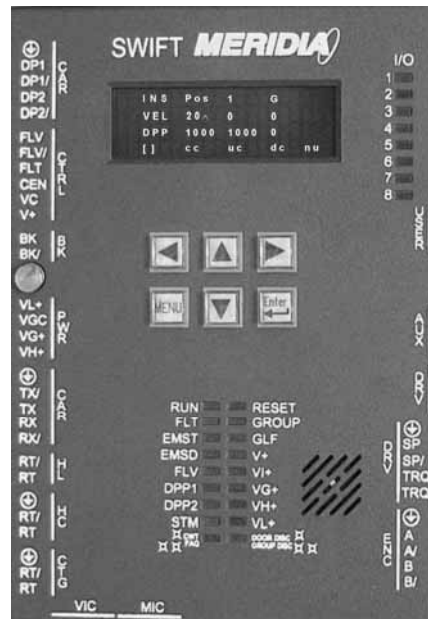

Figure 3-15



Parameter Adjustment

Note: To change a parameter value, use the arrow keys to scroll to the parameter desired. Press <ENTER>. This will cause the last digit of that value to blink. Use the ▲▼ keys to change this value. Use the ◀▶ keys to move from digit to digit. Press <ENTER> to save desired value.

Note: These changes are only saved and not written to flash memory until the WRT command has been selected under the Car Commands menu.

1. Measure resistance between BR1 & BR2 with brake leads connected. Record this value for calculation of parameter BRR. (Brake Board located on Rear of Swing Door.)
2. Press <MENU> button until you get to Main Menu.
3. Scroll to **Car Parameters** and press <ENTER>.
4. Scroll to **Brake** and press <ENTER>.
5. Verify the parameters for the Brake Adjustments. [See Table B.]
6. Press <MENU> once to return to the **Car Parameters** sub-menu.
7. Scroll to **Control** and press <ENTER>.
8. Set parameters listed in Table C.

Control Parameters

Parameter	Description
CCN =	car number in the group you are working on.
BED =	Building Elevator Number
RPM =	as per wiring diagrams power distribution page (top Speed RPM) (Note: Same as Drive A1 F11 motor speed)
PPR =	Per motor encoder name plate. (Note: Same as Drive F10 encoder pulses per revolution.)
SCT =	Set to 25
LAG =	Set to 15

Table C

9. Press the <MENU> key to return to **Car Parameters** sub-menu screen.
10. Scroll to **Pos** and press <ENTER>.

DPF Requirements

Rail Encoder	DPF = 2552
Tape	DPF = 320
Governor Shaft Encoder	DPF = PPR/FPR
FPR = (Governor Sheave diameter* X 3.1416) / 12	
PPR = Encoder pulses per revolution on data tag.	

Table D (* in inches)

11. Verify the **DPF** parameter matches what is required for this job. Change as above if required. [See Table D]
12. Press <MENU> and return to the sub-menu screen.
13. Scroll to **Vel** and press <ENTER>.

Brake Parameters

Parameter	Range	Default	Units	Adjustment Description
BCL	0-32	16	1/64 SEC	Brake Control Lift timer delay. Note: Only used on VVVF drives.
BHV	0-500	JOB	VOLTS	Brake Hold Voltage. Set to desired Brake Hold voltage. (Normally 80% of BLV.)
BLT	0-320	1	1/64 SEC	Brake Lift Time. Set at 1 for Fasted Brake Pick on Inspection.
BLV	10-500	JOB	VOLTS	Brake Lift Voltage. Set to desired Brake Pick voltage. (Must not exceed 90% of BMV.)
BMA	1-20	JOB	AMPS	Brake Maximum lift Amps. Set at 1 for Non-serial Brake board. If using large current Brake board, set to match jumper configuration.
BMV	20-500	JOB	VOLTS	Brake Maximum Line Voltage. Set to match AC incoming to Brake board. (Normally 145 or 290 VAC)
BRR	0-65535	JOB	NUMERIC	Brake regulator resistance configuration. Once BHV is set, increase or decrease the output at BK+and BK- to equal the BHV setting +/- 5VDC.

Table B



14. Set the **IVE** parameter to 20 and press <ENTER>.
15. Press <MENU> until you return to the Main Menu.
16. Scroll to **Car Hoistway** and press <ENTER>.
17. Temporarily set parameters **ESV**, **ETV**, and **TSV** to contract speed minus 10 fpm (feet per minute).
18. Press <MENU> until you return to the Main Menu.
19. Scroll to **Car Commands** and press <ENTER>.
20. Scroll down to **WRT** Command and press <ENTER>.

SETTING UP THE DRIVE

Magnatek DSD 412 Parameter Setup and Check

1. With the controller mainline, CB2 and CB6 on, look at the drive display (SCDU) and verify it is active.

Note: *On a normal power-UP the SCDU will show "P-UP". If there is a number shown it is a fault number and should be disregarded at this time.*

2. Verify the parameters in the drive match actual job conditions. See Quick Reference (Table E).

- A. Use the UP or DN (down) arrow keys on the drive to select the parameter number required.

Note: *Both the DATA and the DATA PEND LEDs are off.*

- B. Press the DATA/FCTN key to display the setting of this parameter.

Note: *The DATA LED is now lit green.*

- C. Use the UP and DN arrow keys on the drive to change this data to the required value.

Note: *Once this setting is changed the DATA PEND LED is now lit red and the DATA LED is off.*

- D. Once you have changed the data to the required setting push the ENT key on the drive.

Note: *Once ENT is pushed, the DATA LED is now green and the DATA PEND LED is now off.*

Saving Drive Parameters

1. To save any changed parameter(s), use the UP or DN arrow keys to function number 994.
2. Turn the NV Ram Protection switch to the off position.

Note: *The un-protect LED will now be lit.*

3. Press the DATA/FNCT key. This will show "REST" on the SCDU.

Note: *The DATA LED will now be lit green.*

4. Press the UP arrow key and the SCDU will now display "SAVE".

Note: *The DATA PEND LED is now lit red.*

5. Press the ENT key.

Note: *The DATA LED should now be lit green.*

6. Place the NV Ram Protect switch back in the on position.

Self Test

1. Place the inspection switch in the on position.
2. Place the NVRAM protect switch in the off position.
3. Press the UP arrow on the drive to display the parameter 998.
4. Press DATA/FCTN key.

Note: *SCDU displays "ENT". Do not push the ENT key yet.*

5. From the CCU Main Menu, select **Car Commands**.

6. Using the ▲▼arrow keys scroll to **SEF** and press <ENTER> to set controller to the Self test mode.



7. Press <ENTER> again to activate.

Note: *This will pull in the required relays on the Meridia controller for the SCR test*

8. Press the ENT key on the SCDU.

Note: *The SCDU will now display "TEST". The Main Contactor (1MA) will pull in and drop briefly then pull in again as it tests the motor.*

9. After the test is complete the SCDU should flash "Pass".

10. Once the test is completed place the NVRAM switch back to the on position.

Self Tune

1. Place the inspection switch in the on position.

2. Place the NVRAM protect switch in the off position.

Note: *The un-protect LED will now be lit*

3. Press the UP arrow on the drive to display the parameter 997.

4. Press DATA/FCTN key.

Note: The Data LED will now be lit.

Note: *SCDU displays "ENT". Do not push the ENT key yet*

5. From the CCU Main Menu, select **Car Commands**.

6. Using the ▲▼ arrow keys scroll to **SEF** and press <ENTER> to set controller to the Self test mode.

7. Press <ENTER> again to activate.

Note: *This will pull in the required relays on the Meridia controller for the SCR test.*

8. Press the ENT key on the SCDU.

Note: *The SCDU will now display "TEST". The Main Contactor (1MA) will pull in and drop briefly then pull in again as it tests the motor.*

9. After the test is complete the SCDU should flash "Pass".

10. Once the test is completed place the NVRAM switch back to the on position.

Note: *At this time the un-protect LED should be off.*

11. Record values in drive Parameters 613 (Arm. Resistance), 614 (Arm. Inductance) and 615 (Measured Field L/R).

12. Take the values recorded in Step 11 and place them accordingly into drive parameters 4 (Arm. Resistance), 6 (Arm. Inductance) and 51 (Measured Field L/R) respectively.

13. Follow Steps described in "Saving Drive Parameters" using the 994 save function on page 3-8.



Note: Refer to the DSD-412 Drive Manual for additional drive information.

Quick Reference for Geared DSD 412 Applications			
Function	Description	Units	Settings
1	Current Limit	%	250
2	Enable Self Tune Values	Off/On	Off
3	Rated Armature Amps	Amps	Motor Nameplate
4	Armature Ohms	Ohms	From Self Tune
6	Armature Inductance	Henrys	From Self Tune
7	Rated Armature Voltage	Volts	Motor Nameplate
8	Irregular Crossover	Rads	500
9	Nominal A/C input Voltage	Volts	Drive Input A/C
10	Encoder Pulses per Revolution	PPR	Encoder Nameplate
11	Motor Speed	RPM	Motor Nameplate
12	Motor Overspeed	%	110
14	Arm. Voltage Sensing	%	25
15	Tach (encoder) Sensing	%	5
16	Gearless Ratio	Ratio	1
17	Rated Velocity (speed)	FPM	Contract Speed
21	Rated Acceleration Rate	F/S/S	4
32	Full Field Sensing	%	30
40	Response	Rads	5
41	System Inertia	Sec	2
42	Stability		1
49	Weak Field Current	Amps	Job Prints
50	Full Field Current	Amps	Job Prints
51	Motor Field Time Constant	Sec	From Self Tune
52	Rated Field Voltage	Volts	Job Prints
53	Standing Field Current	Amps	Job Prints
54	Field Response	Rads	5
55			Same As 9
56	Field Strength Speed	%	90
57	Field Weaken Speed	%	80
58	Field Strength Rate	Sec	2
59	Field Weaken Rate	Sec	2
63	Direction UP/DN Bit PickUP	%	0.01
80	Overspeed Test Enable	Off/On	Off
81	Overspeed Multiplier	X	1
82	Reference Multiplier	X	1
83	Motor Overload Time Out	Sec	90
84	Motor Overload Level		1
85	Current Delay Ramp	Sec	0.2
86	LPR Delay Time	Sec	0.3
95	Analog Output 0	PU	0 (speed ref.)
96	Analog Output 1	PU	0 (speed ref.)
104	I Serial Gain Switch	Off/On	On
105	Gain Switch Speed	% Speed	0.05
107	Tach (encoder) Rate Gain		0
108	Gain Reduce	X	0.2



Quick Reference for Geared DSD 412 Applications			
Function	Description	Units	Settings
View Only Functions			
600	Car Speed	FPM	N/A
601	Motor RPM	RPM	N/A
602	Speed Reference	FPM	N/A
603	Pretorque Input	%	N/A
609	CEMF VDC	Volts (DC)	N/A
610	Motor Armature Voltage	Volts (DC)	N/A
611	Motor Armature Current	Amps. DC	N/A
612	Motor Field Current	Amps. DC	N/A
613	Measured Motor Resistance	OHMS	N/A
614	Measured Motor Inductance	HENRIES	N/A
615	Measured Field L/R Time Constant	Sec.	N/A
616	Speed Error	F/M	N/A
617	AC Line Frequency Parameter	Hz	N/A
618	Heatsink Temperature	C°	N/A
619	AC Line Voltage	Volts (AC)	N/A
Internal Command Controls			
994	Used to Save Parameters		
997	Self Tune Test		
998	Self Diagnostics		

Table E



MOVING THE CAR ON INSPECTION FOR SERIAL DRIVES

1. Verify the CCU is displaying the **Car Status**.
[See Figure 3-16.]

Car Status Display

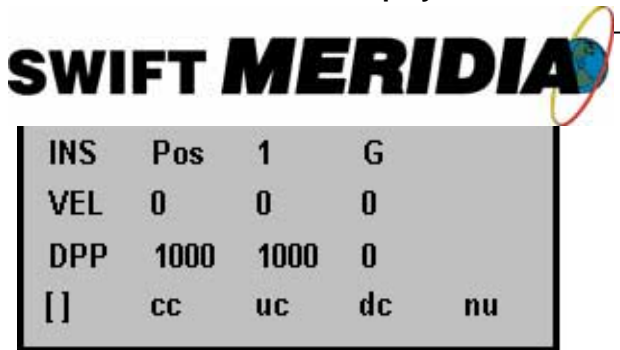

Figure 3-16

2. Uncouple the motor encoder from machine.
3. By hand, rotate the encoder in the UP direction. Verify that P600 Car Speed on drive displays a positive direction. Do the same for the DOWN for a negative speed. To change the direction, swap the Encoder wiring to the DSD 412 as follows: A and A or B and B.

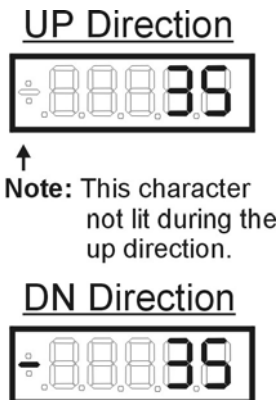

Figure3-17

4. Recouple the encoder to Motor. Briefly press the UP button on the Panel Test Station while observing the drive sheave.

Note: Should the drive sheave turn in the UP direction at an uncontrolled speed, swap the A and A wires (also the B and B wires) at the drive from the encoder.
[See Figure 3-18.]

Note: Should the drive sheave turn in the opposite direction at an uncontrolled speed, swap MF+ and MF- from the motor.

5. Verify that the car speed is equal to the speed demand (IVE parameter in the control system) during initial setup. It is unlikely that there will be a cartop encoder for speed feedback, so a handheld tachometer may be needed. Adjust the drive parameter 11, motor speed (RPM), to make the car velocity equal to the speed command.

Motor Encoder Wiring

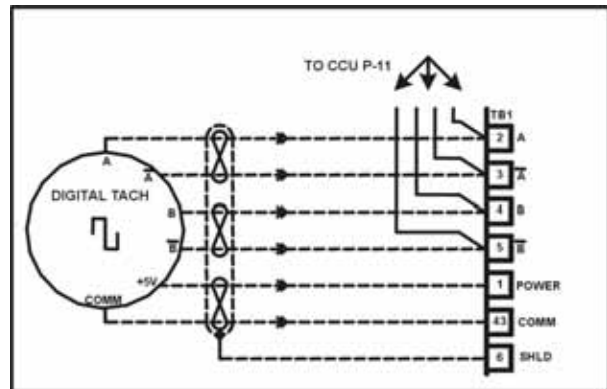

Figure 3-18

6. Verify the car now moves UP when the UP button is pressed and down when the down button is pressed.
7. Set PPR parameter to equal the value of Drive parameter 10 (Encoder Speed).
8. Set RPM to equal the Drive parameter 11 (Motor Speed).



- Rotate the status screen to the VIC screen.

VIC Status

Vic	Cm	20FPM
ELcp	1342	Esf <input type="checkbox"/>
Sif <input type="checkbox"/>	Isf <input type="checkbox"/>	GLf <input type="checkbox"/>
Mic Bk	Cm	100V 50%

Figure 3-19

- Run the car in the **UP** direction. Verify that the VIC direction arrow is in the same direction. Do the same for the DOWN. The VIC direction comes from the motor encoder. To change the direction, swap the Encoder wiring to the **CCU** as follows: A and B, A and B.

INSPECTION OPERATION

Note: The brake assembly **MUST** be in good working condition in order to achieve proper brake operation. Do not continue until all operational problems have been corrected.

- Set the IVE parameter at a safe working speed and save the new parameter.
- Verify that the brake is fully picking when the car runs. If not further adjustment of the brake or brake parameters may be required.
- Verify brake can stop and hold 125% of the capacity of the elevator in the down direction. See manufacturer's information for details.
- Verify the brake drops when the car stops.
- Remove temporary jumper TIC – TIA to allow the car to run from the Car Top Station and disable the panel test buttons.
- Remove temporary jumpers to II to ICS.
- Verify that the Panel Test run buttons are inactive.

- Verify the Governor switch opens the safety circuit and the car does not run.

Note: When wiring in a car top run station make sure the stop switch is also wired in and functioning. [See Figure 3-20.]

Car Top Inspection Wiring

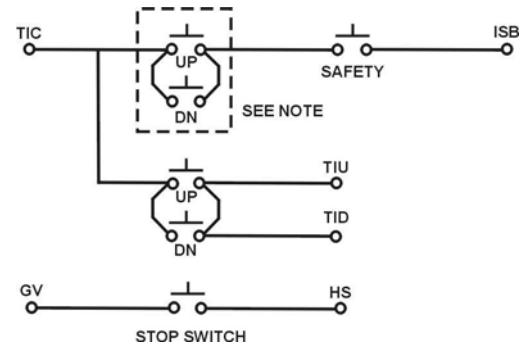

Figure 3-20

Note: Make these connections only if two-pole buttons are used.

